

H-AT

Hydraulic Torque Wrench



Application

- **Hydraulic torque wrenches** with two hydraulic hose systems for tightening or loosening heavy bolt connections.
- **alkitronic® H-AT** hydraulic torque wrenches from 80 up to 53,100 ft.lbs (110 up to 72,000 Nm) for threads of M14 and larger.
- **No checking needed:** High repeatability $\pm 3\%$ for the same bolting process.

Advantages

- **Robust and ergonomic:** Hard-wearing, ergonomically shaped housing design made of high strength Aluminium-Titan-Alloy.
- **Simple and low weight:** Easy handling and low weight. Simply replug the square drive from tightening to loosening.
- **Durable and safe:** Bevelled torsion-resistant, highly-loaded one piece design. Higher work-safety due to an advanced and sustainable design.
- **High economic efficiency:** Long operating life, reliable bolting, low maintenance.

alkitronic® specials

- **alkitronic® H-AT** developed for flexible applications in restricted space, ¹ support arm incrementally adjustable (see drawing below).
- **High flexibility:** Convenient, secure and reliable pivoting one-piece joint couplings. Pivotal in two levels (360° horizontally, 180° vertically).
- Robust, rough toothed ratchet for **high torque accuracy**.
- **Solid, precise, especially powerful:** Unique design of the drive pawl.



Technical Data

Type		H-AT 1	H-AT 2	H-AT 3	H-AT 5	H-AT 8	H-AT 10	H-AT 20	H-AT 25	H-AT 35	H-AT 50	
Torque range (approx.)	Nm	110-1120	180-1840	450-4510	750-7530	1080-10780	1550-15520	2660-26660	3470-34730	4860-48600	7200-72000	
	ft.lbs	80-826	133-1357	332-3326	553-5554	797-7951	1143-11447	1962-19663	2559-25615	3585-35845	5310-53100	
Square drive size		3/4"	3/4"	1"	1 1/2"	1 1/2"	1 1/2"	2 1/2"	2 1/2"	2 1/2"	2 1/2"	
Height	H2	mm	108,1	131	176,5	199	217	232	270	297	332	341
Length	L1	mm	110,8	144,5	178	210,5	222	245,5	307,5	323	372,5	400
Length	L2	mm	139,3	173	229	270,5	293	317,5	383,5	401	496,5	516
Radius	R	mm	20,5	26	34	39	47	51	59	66	77	81
Radius	R2	mm	68,3	85	114	137	153	154	186	199	214	259
Width	B1	mm	42	50	68	80	90	100	120	137	153	160
Width	B2	mm	54	66,5	89,5	100	120	128	153	159,5	167	178
Weight (approx.)	kg	mm	1.8	2.5	5	8	11	15	26.5	35	50	87

Important for the exact reproducibility of the specified torque is a pressure of max. 700 bar. Repeatability $\pm 3\%$. For a fast, safe and reliable operation of the hydraulic wrenches, we recommend our **alkitronic® NOVA** or **alkitronic® VELOX** hydraulic pumps (700 bar pressure, can be used worldwide in all mains grids 100-253 V / 45-66 Hz).

Model **alkitronic® H-AT**

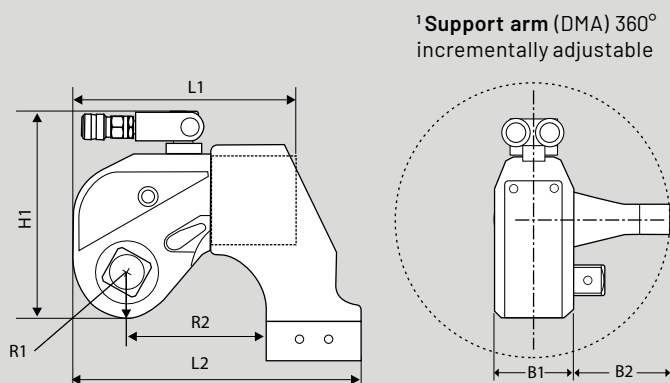

alkitronic® H-AT
Use in a wind power plant

alkitronic®
HOME OF TORQUE POWER

alkitronic® products
Made in Germany by

alki TECHNIK GmbH
Development, Production and
Distribution of Bolting Systems

Unterlettenweg 4
85051 Ingolstadt
Germany

fon +49 841 97499-0
fax +49 841 97499-90

info@alkitronic.com
www.alkitronic.com